

605S

Passage gate



Features

- Stainless steel construction.
- Side & top pass indicators.
- Motor driven gates 180° (90° + 90°) operation.
- Suitable for internal and external use.
- Activated by dry contact or via TTL input 5-48v.
- Can be activated by most access control units and token systems.

Options

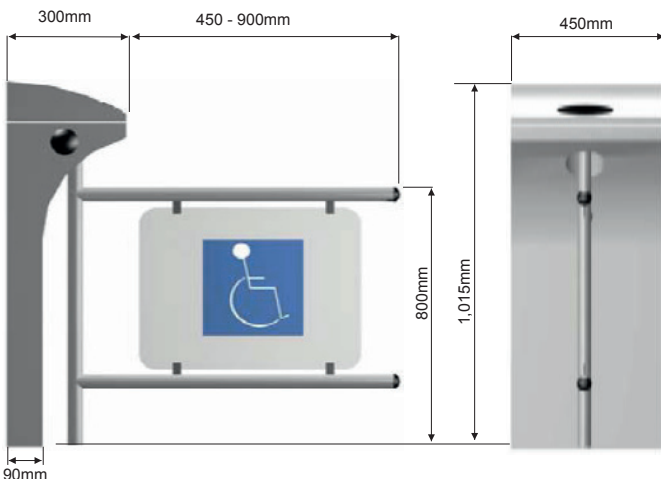
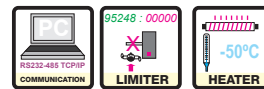

Specification

- Dimensions:** 450 x 1015 x 300 + Arm length (450-900mm).
- Weight:** 40kg.
- Body:** 2 mm (304) Stainless Steel or Powder Coated sheet metal. Both alternatives are protected against water for external use.
- Arms:** Ø 40 x 2.5mm wing flap can be dismantled. (304) Stainless Steel.
- Power:** 220 v. 50 Hz. Standby ~8 W. Max. ~65W.
- Temperature:** -10°C/+45°C (Opt. -50°C with heater unit).