

602D

Double half height turnstile

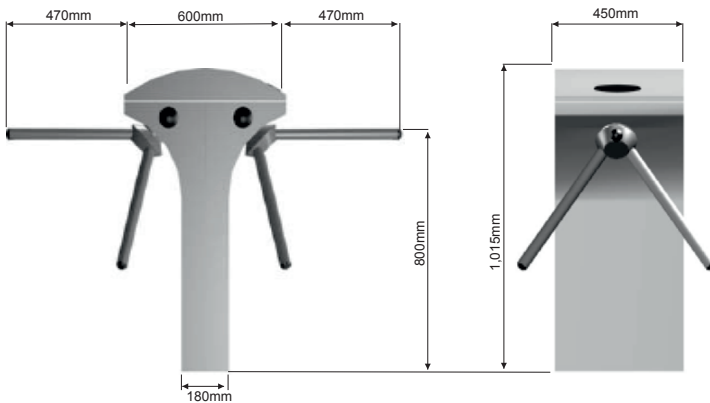

Features

- Single central structure with two independent rotors.
- Stainless steel construction.
- Side & top pass indicators.
- Both rotors with full bidirectional control.
- Suitable for internal & external use.
- Activated by dry contact or via TTL input 5-48v.
- Can be activated by most access control units and token systems.

Options

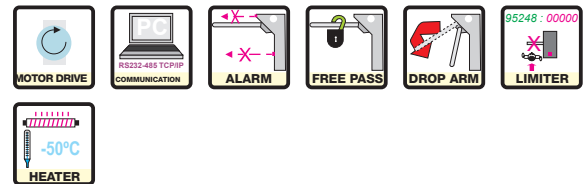

Specification

- Dimensions:** 450 x 1015 x 600 + Arm Length (2 x 470mm).
- Weight:** 56kg.
- Body:** 2 mm (304) Stainless Steel or Powder Coated Sheet Metal. Both alternatives are protected against water for external use.
- Arms:** Ø 40 x 2.5mm Stainless Steel.
- Power:** 220 v. 50 Hz. Standby ~22W. Max. ~120W.
- Temperature:** -10°C/+45°C (Opt. -50°C with heater unit).
- Flow Rate:** Number of People/minute 12 to 40 max each side dependant on environment & access control system.