

T703S

Half height turnstile

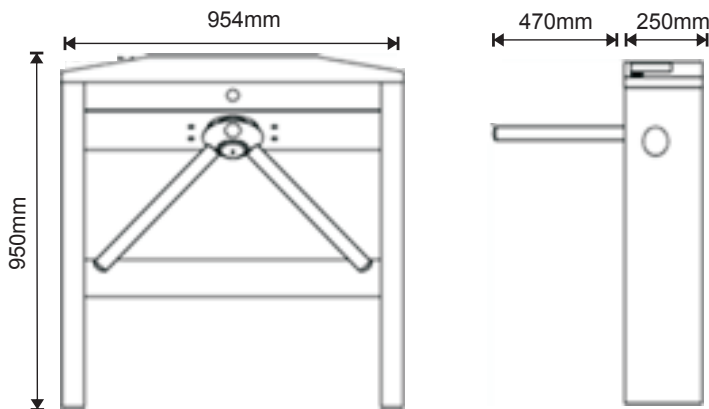

CE



Features

- Activated by dry contact or via TTL input 5-48v.
- Can be controlled via RS 232, RS 485 or LAN network.
- Can be integrated with all kinds of access control units and token systems..

Options



Specification

- Dimensions:** 954 x 950 x 250 + Arm Length (470mm).
- Weight:** 34kg.
- Body:** 1.5 mm (304) Stainless Steel or Powder Coated Sheet Metal. Both alternatives are protected against water for external use.
- Arms:** Ø 40 Stainless Steel.
- Power:** 220 v. 50 Hz. Standby ~11W. Max. ~60W.
- Temperature:** -10°C/+45°C (Opt. -50°C with heater unit).
- Flow Rate:** Number of people/minute 40 nominal dependant on environment & access control system.