

400E

Wall-mounted Turnstile

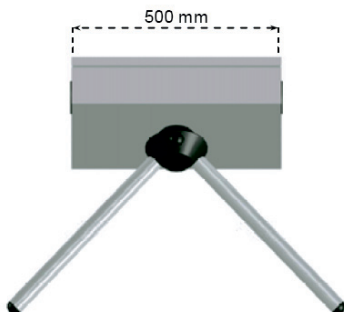
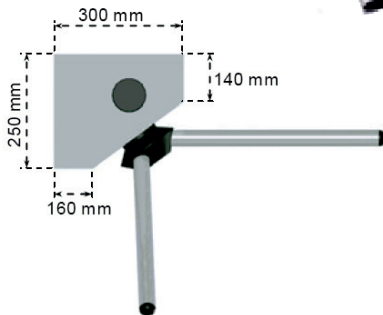

Features

- Stainless steel construction.
- Side pass indicators.
- Full bidirectional control.
- Activated by dry contact or via TTL input 5-48v.
- Can be activated by most access control units and token systems.

Options



Specification

Dimensions: 500 x 255 x 300 + Arm length (470mm).

Weight: 22kg.

Body: 1.5 mm (304) Stainless Steel or powder coated sheet metal.

Arms: Ø 40mm (304) Stainless Steel.

Power: 220 v. 50 Hz. Standby ~11W. Max. ~60W.

Temperature: -10°C/+45°C (Opt. -50°C with heater unit)

Flow Rate: Number of People/minute 40 nominal dependant on environment & access