

602S

Waist height turnstile



Features

- Stainless steel construction.
- Side & top pass indicators.
- Full bidirectional control.
- Suitable for internal and external use.
- Activated by dry contact or via TTL input 5-48v.
- Can be activated by most access control units and token systems.

Options

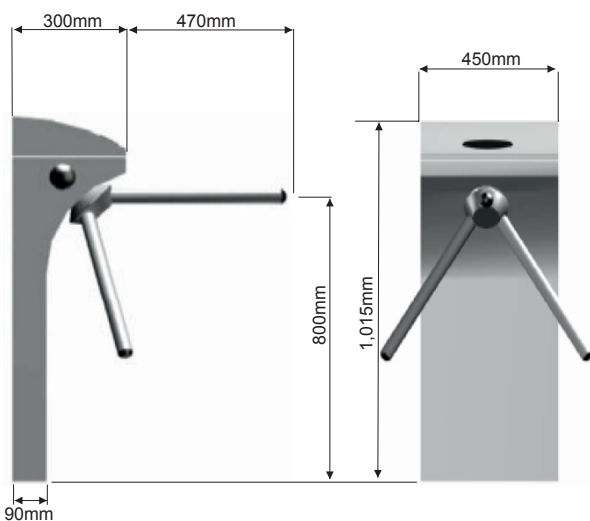
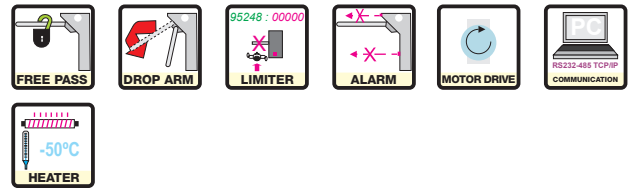

Specification

- Dimensions:** 450 x 1015 x 300 + Arm length (470mm).
- Weight:** 36kg.
- Body:** 2 mm (304) Stainless Steel or Powder Coated Sheet Metal. Both alternatives are protected against water for external use.
- Arms:** Ø 40 x 2.5mm (304) Stainless Steel.
- Power:** 220 v. 50 Hz. Standby ~16W. Max. ~130W.
- Temperature:** -10°C/+45°C. (Opt. -50°C with heater unit).
- Flow Rate:** Number of people/minute 12 to 30 max. dependant on environment & access control system.